

AN_65XX_063

APRIL 2011

A Low-Current Power Supply for the 71M65XX Metering ICs

Introduction

Capacitor-coupled power supplies have been used for a long time in low-cost residential single-phase meters. These power supplies work without transformers and generate a voltage drop across a high-voltage capacitor that is typically in the 200 nF to 680 nF range. This approach is simple and economical, but efficiency is low, not allowing load currents of more than a few milli-amperes. The inefficiency of this design is due to the fact that only the negative voltage of the AC input is used, which results in an asymmetrical load.

This Application Note presents an improved design for the capacitive power supply.

Simple Capacitive Power Supplies

Limitations of Capacitive Power Supplies

The capacitor in the front end of this type of power supply introduces a phase shift close to 90°. This means that the ripple generated further downstream on the V3P3 voltage and ground is also close to 90° with respect to the line voltage.

An electronic meter calculates the energy outputs with the following methods:

- The real energy (Wh) output is based on voltage and current samples
- The reactive energy (VARh) output is based on voltage samples shifted by 90° and current samples

It follows from the above that a ripple with 90° phase shift relative to the line voltage will not affect the real energy measurements, whereas it will significantly affect the reactive energy measurements. Since low-end residential meters typically do not measure reactive energy, a capacitive power supply is a good choice for this type of meter.

Ripple should be a consideration for meter design, if both Wh and VARh are measured and a capacitive power supply is used. Low-current accuracy depends on ripple and minimum signal from the shunt (along with other factors such as PCB layout, ripple rejection, and wiring). For shunt values below 200 $\mu\Omega$, ripple should be closely examined. If a significant and repeatable increase in VARh error at low current is encountered, the *QUANT_VAR* mechanism of the CE codes can be used to compensate for the effect of capacitive power supply. Please see the Demo Board User Manual (DBUM) associated with the Maxim Metering IC in question for details.

An Example of a Capacitive Power Supply

To demonstrate the limitations of simple capacitor-coupled power supplies, simulations were performed with a typical circuit as shown in Figure 1 at various AC supply voltages and load currents. This circuit has an input capacitor of 0.47 μF . To follow many metering conventions, the net connecting the AC input and the positive board reference is labeled "LINE". Table 1 lists some results. As can be seen, the apparent power (S) at 240 VAC exceeds 10 VA, whereas at 115 VAC and 8 mA load, a long time (i.e. 4 seconds) is needed for the output voltage to stabilize. At 10 mA load current, typical for a 71M6521, for example, the output never reaches the required 3.3 VDC. At 50 Hz and 115 VAC, the results will even be worse, since the reactance of the capacitor will be reduced by 20%.

When we try to increase the output current, we find that the input current has to be increased two-fold, due to the low efficiency of this design, and very soon, the apparent power consumed by the input exceeds the maximum limit defined in most metering standards and regulations.

It becomes clear that this type of power supply is only useful for small load currents and for relatively narrow ranges of the input voltage.

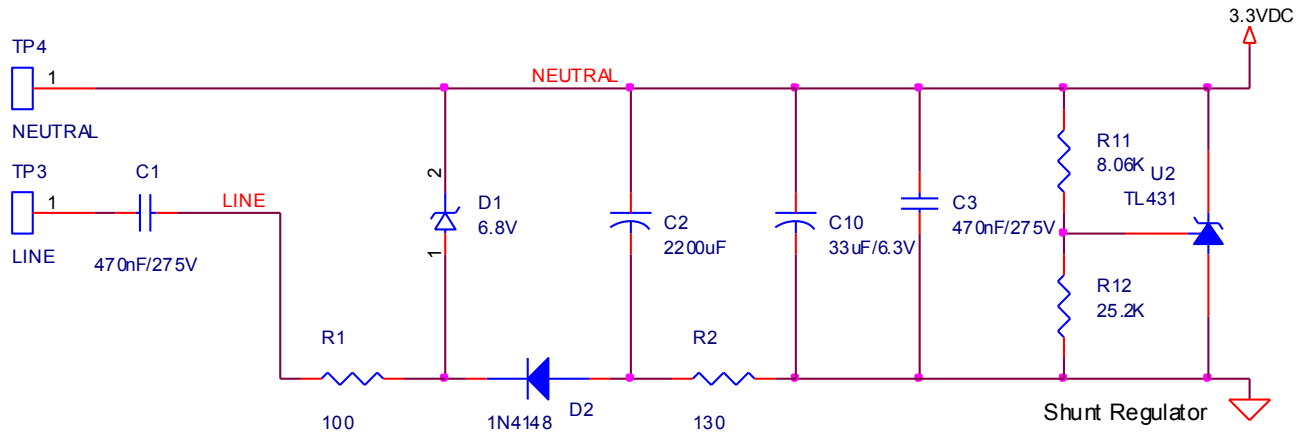

Figure 1: Simple Capacitive Power Supply

Table 1: Performance Characteristics of the Simple Capacitive Power Supply

f [Hz]	CIN [nF]	VIN [Vrms]	iL [mA]	iIN peak [mA]	S [VA]	Stabilization time [s]
60	470	115	8	30	2.44	4.0
60	470	115	10	30	2.44	unstable
60	470	240	8	62	10.52	0.70
60	470	240	10	62	10.52	0.75

The Improved Low-Current Power Supply

The new circuit works off both positive and negative half waves of the AC input and thus offers a balanced load to the AC source.

The principle of the low-current power supply is that it uses the same current to charge several capacitors at the same time. This method immediately results in higher energy storage and efficiency, which translates to a lower input current for the same load, reduction of the input capacitor value and immediate cost savings. This power supply is also modular: More capacitors can be added that will charge in series and still consume the same low current. However, during the discharge cycle, the serial capacitors are arranged in parallel, resulting in more energy fed to the output.

Schematics

The schematics for the low-current power supply are shown in Figure 2. The value of the input capacitor has been reduced to less than 50% of the value used in the simple design shown in Figure 1. The output stage uses the same shunt regulator (e.g. the TL431), and the output capacitor (C4) is at the same value that was used in the simple capacitive power supply.

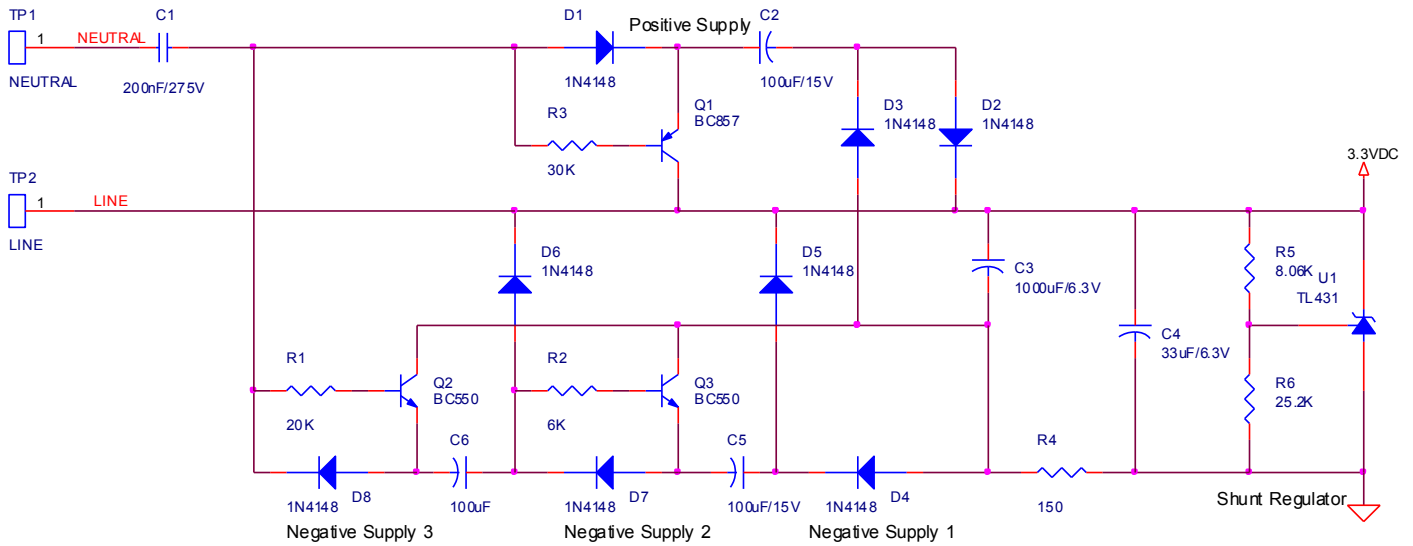

Figure 2: Improved Low-Current Power Supply

Function

The function of the circuit involves two different mechanisms: During the charge cycle, various smaller capacitors are charged. During the discharge cycle, the previously charged capacitors charge the large reservoir capacitor C3.

- Positive charge cycle: When NEUTRAL is more positive than LINE, C2 is charged only (via D1 and D2).
- Negative charge cycle: When LINE is more positive than NEUTRAL, C3 is charged in series with C6 and C5 (via D4, D7, and D8). This takes advantage of using same current to charge all capacitors.
- Positive discharge cycle: C6 and C5 in parallel discharge into C3 (via Q2 and Q3).
- Negative discharge cycle: C2 discharges into C3 (via Q1 and D3).

The real efficiency gain comes from using the transistors to connect the smaller capacitors in parallel with C3 for discharge.

Performance

The circuit behaves well with changes of the AC input frequency, as shown in Table 2: Even at the lowest input frequency, the supply stabilizes after 0.5 seconds.

Table 2: Frequency Characteristics of the Low-Current Power Supply

f [Hz]	CIN [nF]	VIN [Vrms]	iL [mA]	iIN peak [mA]	S [VA]	Stabilization time [s]	Ripple [mV]
45	200	240	8	19.5	3.31	0.5	
50	200	240	8	21	3.56	0.4	
60	200	240	8	25.3	4.29	0.4	0.4
65	200	240	8	27.7	4.70	0.3	

Note that the ripple voltage was simulated with ideal capacitors for both the simple capacitive supply and the low-current supply. Practical achievable values may be different.

As Table 3 shows, the circuit works with input voltages as low as 100 VAC, even at only 50 Hz frequency with a load current of 8 mA.

Table 3: Voltage Characteristics of the Low-Current Power Supply

f [Hz]	CIN [nF]	VIN [Vrms]	iL [mA]	iIN peak [mA]	S [VA]	Comment
50	200	240	8	21	3.56	
50	200	115	8	10	0.81	
50	200	100	8	9	0.64	
50	200	80	8	7	0.40	Output not stable

Increasing the load current is tolerated to up to 20 mA, at 50 Hz and 240 VAC input, as Table 4 shows. The apparent power consumed stays below 4 VA.

Table 4: Load Characteristics of the Low-Current Power Supply

f [Hz]	CIN [nF]	VIN [Vrms]	iL [mA]	iIN peak [mA]	S [VA]
50	200	240	8	21	3.56
50	200	240	10	21	3.56
50	200	240	15	21	3.56
50	200	240	20	21	3.56

Much larger load currents can be delivered when the input capacitor C1 is increased to 470 nF, as shown in Table 5.

Table 5: High Load Characteristics of the Low-Current Power Supply

f [Hz]	CIN [nF]	VIN [Vrms]	iL [mA]	iIN peak [mA]	S [VA]
50	470	240	8	50	8.49
50	470	240	16	50	8.49
50	470	240	32	50	8.49

Component Selection

The simulation described below is based on a real shunt-regulator but it uses ideal capacitors. Obviously, the results will differ with real capacitors. Selection of the proper capacitors is critical for reliability and ripple performance. For tantalum electrolyte capacitors, a wide variety of ESR (electrical series resistance) is available, which can range from a few mΩ to 3Ω or more.

- C3: A 16 VDC or higher rated capacitor should be used
- C4: A capacitor with low ESR should be used. For power supplies used in single-phase shunt-based meters, the value for C4 should be increased to at least 100 μF in order to reduce the ripple voltage.

Component Cost

The following cost considerations favor the new low-current power supply over the simple capacitive power supply:

- 1) The cost for the high-voltage capacitor is lower since only 50% of the capacitance is required for the same output current. Capacitors rated at 630 V are in the \$1.50 price range for 0.47 μF but can be purchased far below \$1 for 0.22 μF capacitance.
- 2) The reservoir capacitor is 1,000 μF as compared to 2,200 μF, which can result in a price difference of \$0.07 in favor of the 1,000 μF capacitor.
- 3) The zener diode 1N4736A is not required for the low-current power supply, which saves \$0.024.
- 4) The transistors, diodes, and additional capacitors are not overly expensive.

Below is a list for the additional diodes, transistors and capacitors required for the low-current power supply, with cost estimates based on typical distributor pricing (Digi-Key) and medium quantities (100,000).

Table 6: Component List

Item	P/N or Value	Description	Cost	Quantity	Extended Cost
1	1N4148	Diode	\$0.020	7	\$0.14
2	BC550	NPN transistor	\$0.035	2	\$0.07
3	BC857	PNP transistor	\$0.027	1	\$0.027
4	33 μ F/6.3V	Tantalum, SMD	\$0.075	1	\$0.075
5	1,000 μ F/16V	Aluminum electrolyte, SMT, 70 m Ω	\$0.48*	1	\$0.48
6	100 μ F/16V	Aluminum electrolyte, through-hole	\$0.030	3	\$0.090
				sum	\$0.882

* cost for < 1,000 pieces – actual cost is likely much lower

It is possible to combine some of the diodes into dual diodes, which reduces the cost and makes procurement and assembly easier. For example, diodes D2 and D3 can be combined, as can diodes D4/D5 and D6/D7.

Circuit Simulation

Files in OrCAD/Cadence format are available from Teridian for PSPICE simulation. Contact your FAE or local distributor for the files. An OrCAD/Cadence Schematic Entry and PSPICE installation is required to perform the simulations.

Two files sets are available:

- 1) Simple capacitive power supply, as shown in Figure 1.
- 2) Low-current power supply, as shown in Figure 2.

Figure 3 shows a simulation screen with the AC input current (blue trace) and the DC output current (red trace).

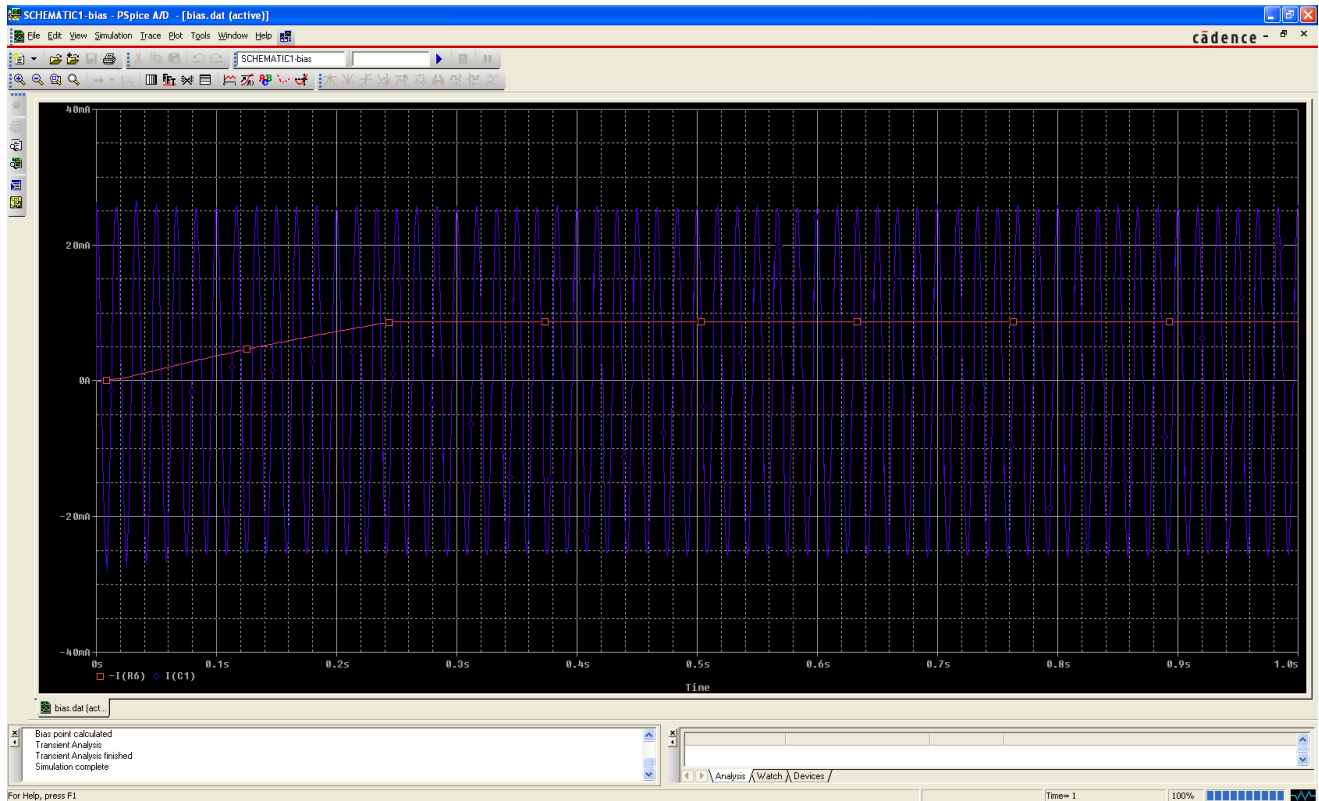

Figure 3: Simulation Screen (OrCAD/CADENCE)

Protective Components

Some care must be taken to avoid high voltage on the capacitors: There is no component that would limit the charging voltage of the capacitors, so in order to avoid capacitor damage due to high-voltage surges on the mains input, it is recommended the use of a bipolar TVS (tranzorb), AC zener diode, or MOV across the LINE and NEUTRAL nets after the high-voltage capacitor. In addition, a 100 Ω resistor should be placed on the high-voltage side to provide a way to drop surge voltage for the TVS, zener diode, or MOV. The protective device is also used in typical conventional power supply designs, which means that no additional cost is incurred due to the improved power supply design.

The low-current power supply schematics with the above mentioned additions are shown in Figure 4.

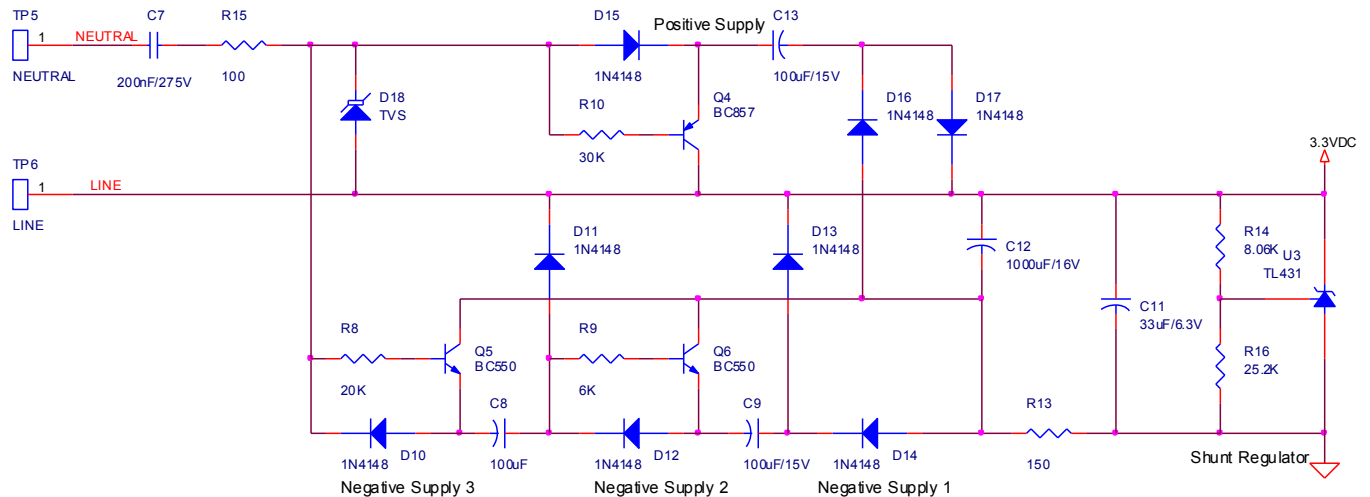

Figure 4: Improved Low-Current Power Supply

Conclusion

The power supply presented in this Application Note is well suited for residential single-phase applications with Wh output, i.e. for use in meters equipped with the Teridian 71M6511, 71M6521, 71M6531, and 71M6541 metering ICs. The supply current is significantly reduced when compared to the conventional design, while no additional cost is incurred.

With certain precautions, this power supply is also useable for meters with VARh output.

It is possible to apply the design principle to poly-phase supplies.

Revision History

Revision	Date	Description
1.0	10/22/2009	First publication – adapted from AN_6541_012.
1.1	4/29/2011	Added explanation of power supply ripple and its effect on the reactive energy measurements and of VARh compensation with <i>QUANT_VAR</i> .

Maxim cannot assume responsibility for use of any circuitry other than circuitry entirely embodied in a Maxim product. No circuit patent licenses are implied. Maxim reserves the right to change the circuitry and specifications without notice at any time.

Maxim Integrated Products, 120 San Gabriel Drive, Sunnyvale, CA 94086 408-737-7600

© 2011 Maxim Integrated Products

Maxim is a registered trademark of Maxim Integrated Products.