

REVISIONS					
P	LTR	DESCRIPTION	DATE	DN	APVD
B4		REVISED PER ECN-21-122181	26OCT2021	RZ	WK

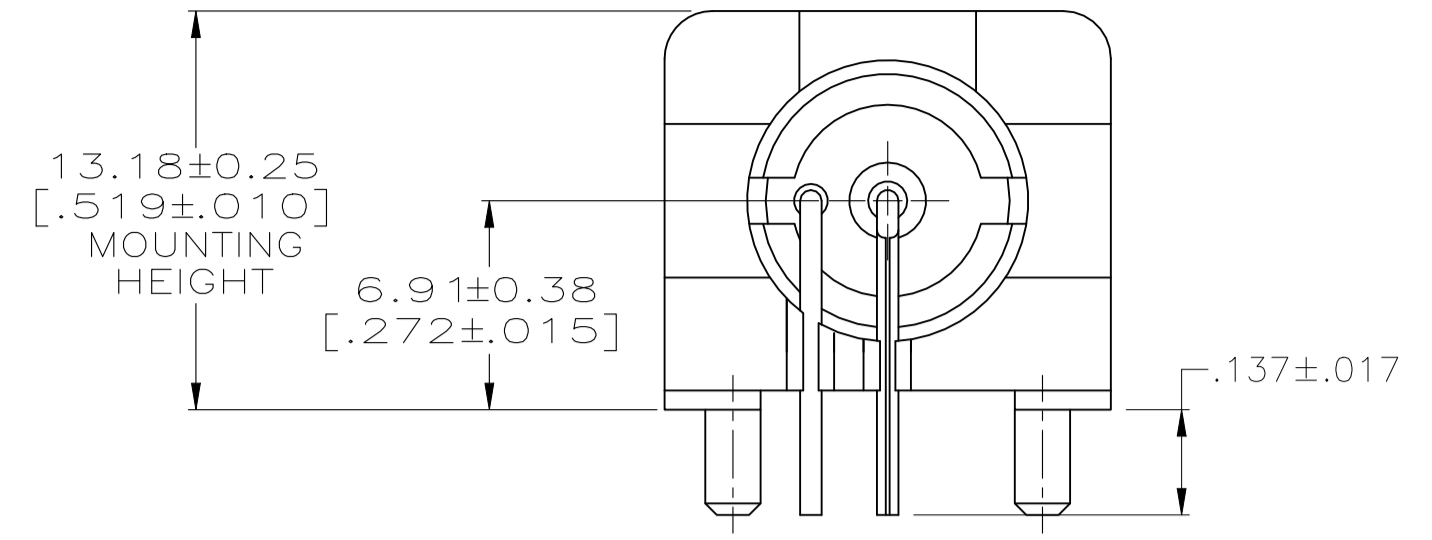

VIEW D
(SAME AS VIEW A
EXCEPT AS SHOWN)

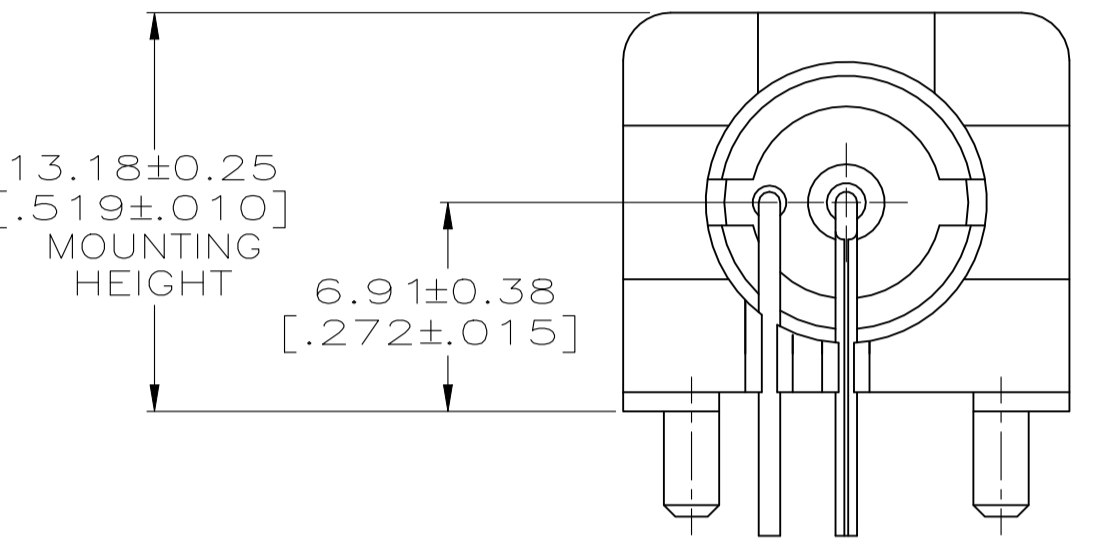

VIEW C
(SAME AS VIEW A
EXCEPT AS SHOWN)

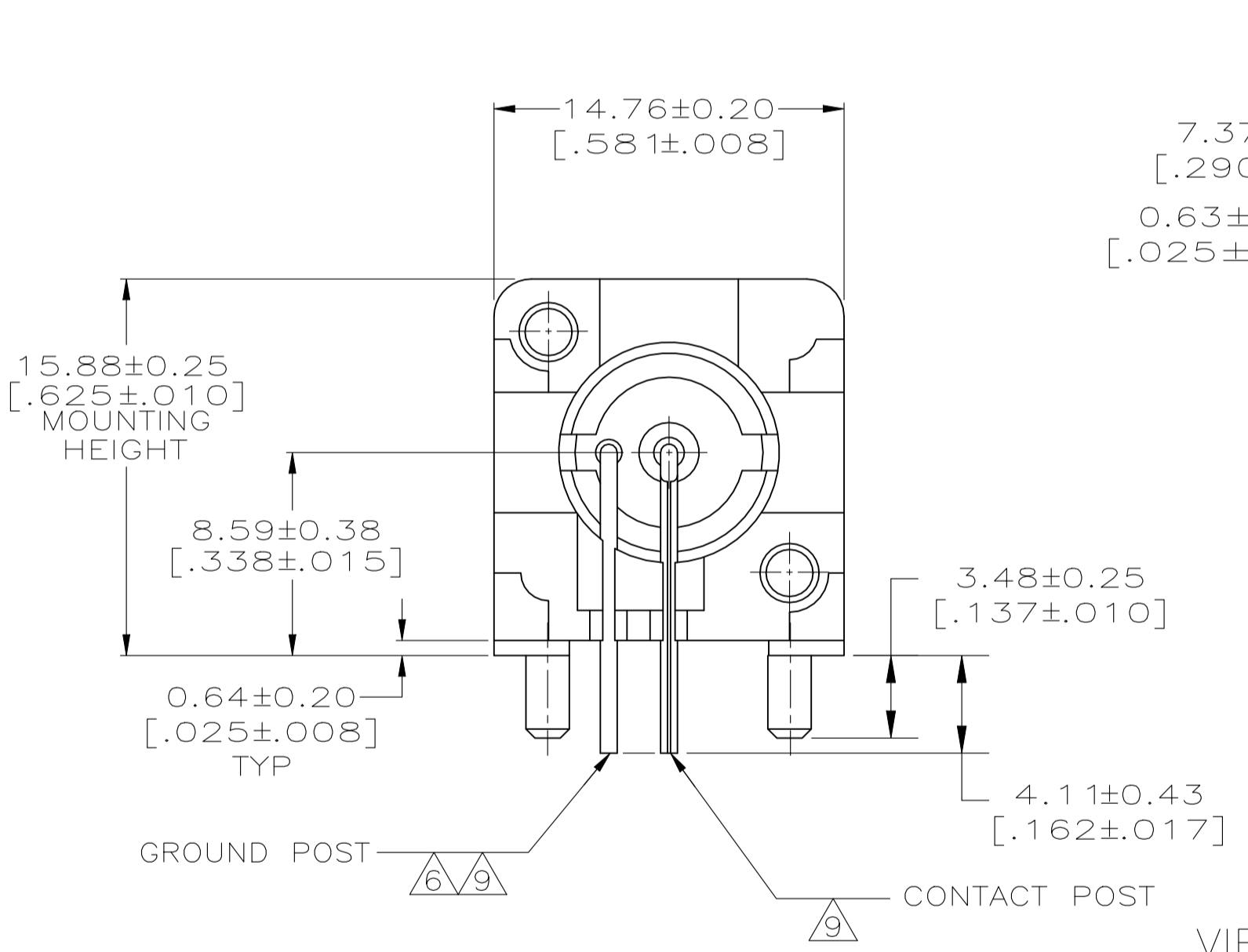

VIEW A

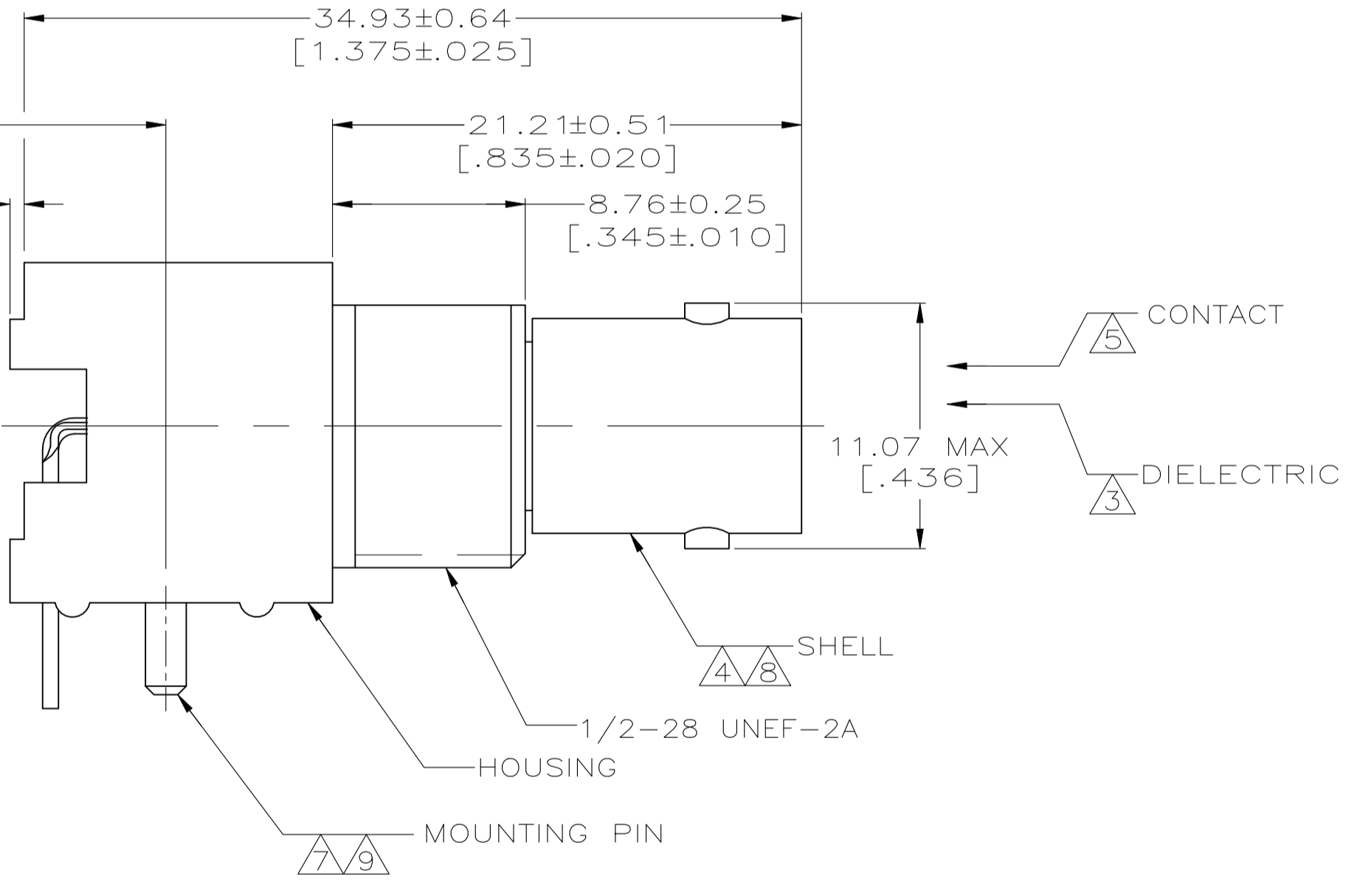
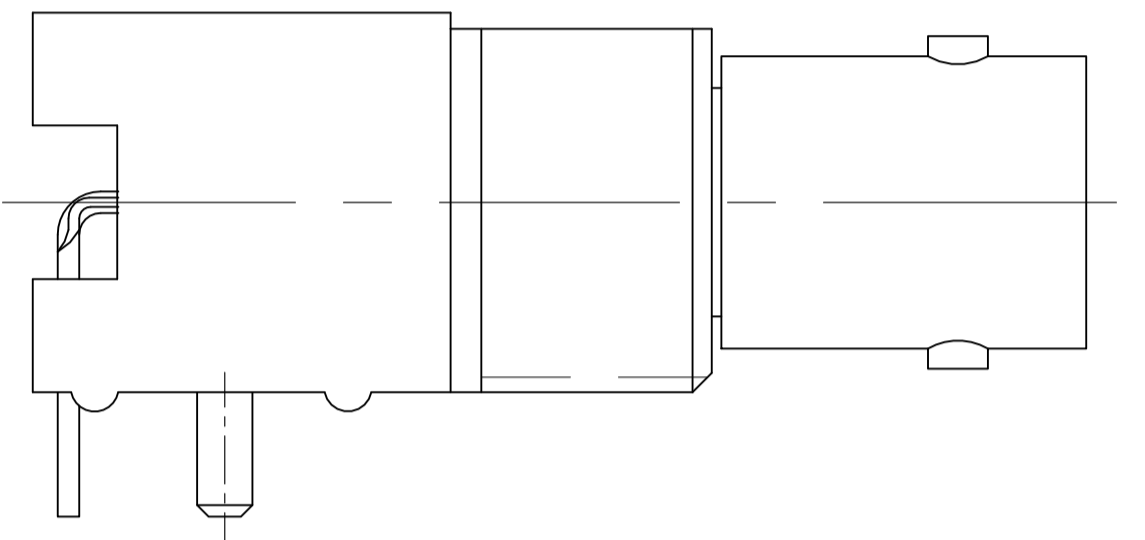
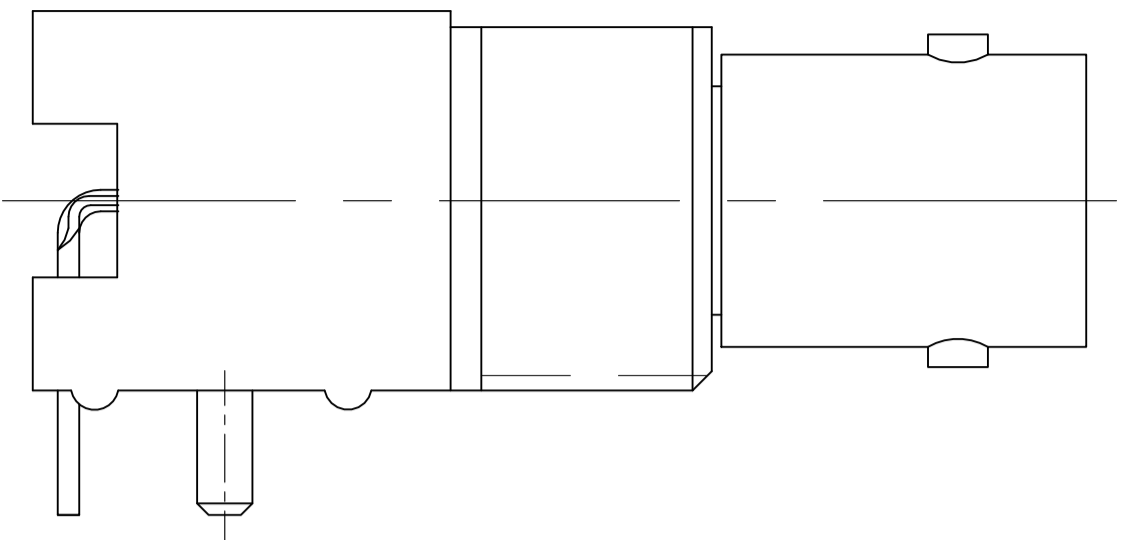

- 1 POLYESTER PBT PER MIL-M-24519, TYPE GPT-15F, UL94V-0 RATED, COLOR:WHITE
- 2 POLYESTER PBT PER MIL-M-24519, TYPE GPT-15F, UL94V-0 RATED, COLOR:BLACK
- 3 POLYMETHYLPENTENE, GENERAL PURPOSE.
- 4 ZINC PER QQ-Z-363.
- 5 PHOSPHOR BRONZE PER QQ-B-750.
- 6 BRASS PER ASTM-B-453.
- 7 BRASS PER ASTM-B-16.
- 8 NICKEL PLATE PER QQ-N-290, 3.81 μm [.000150] MINIMUM THICK.
- 9 TIN PLATE PER ASTM-B-545, 3.81 μm [.000150] MINIMUM THICK.
- 10 GOLD PLATE PER MIL-G-45204, 0.76 μm [.000030] MINIMUM THICK.
- 11 GOLD PLATE PER MIL-G-45204, 1.27 μm [.000050] MINIMUM THICK.
- 12. SEE INSTRUCTION SHEET 408-2769.
- 13. RECOMMENDED TORQUE FOR NUT(part 2) : 0.9 Nm.

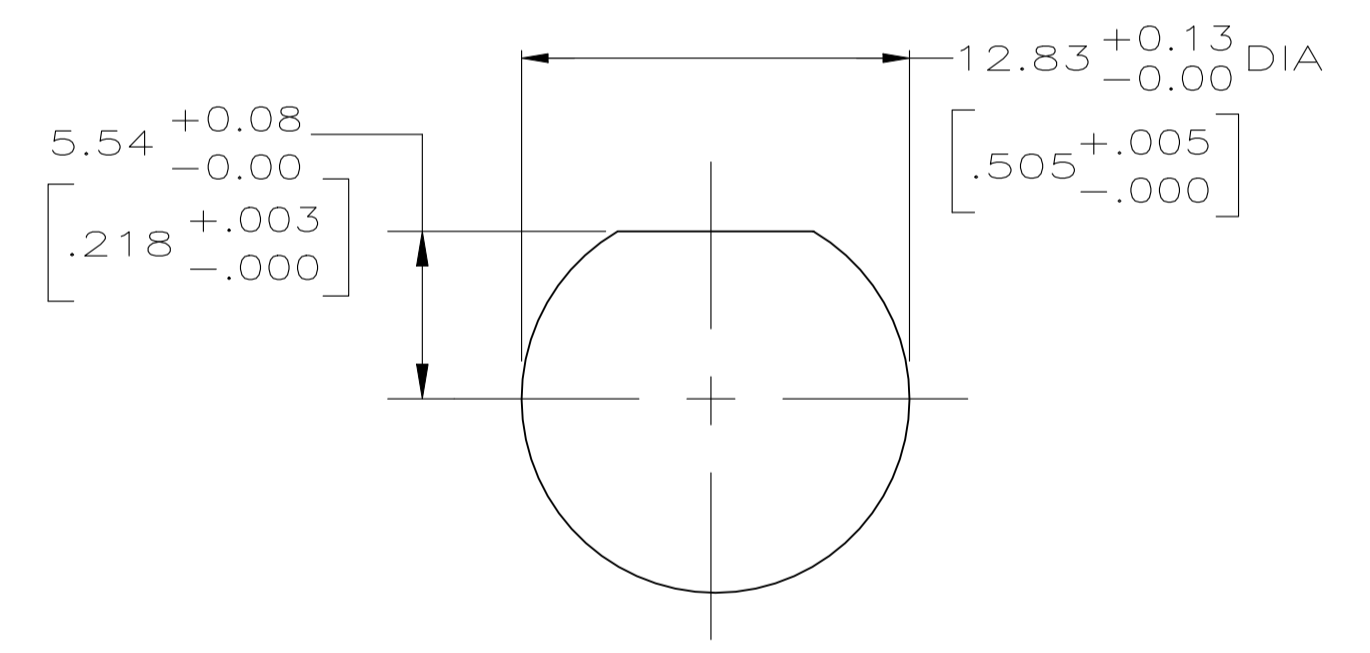

RECOMMENDED PANEL CUTOUT

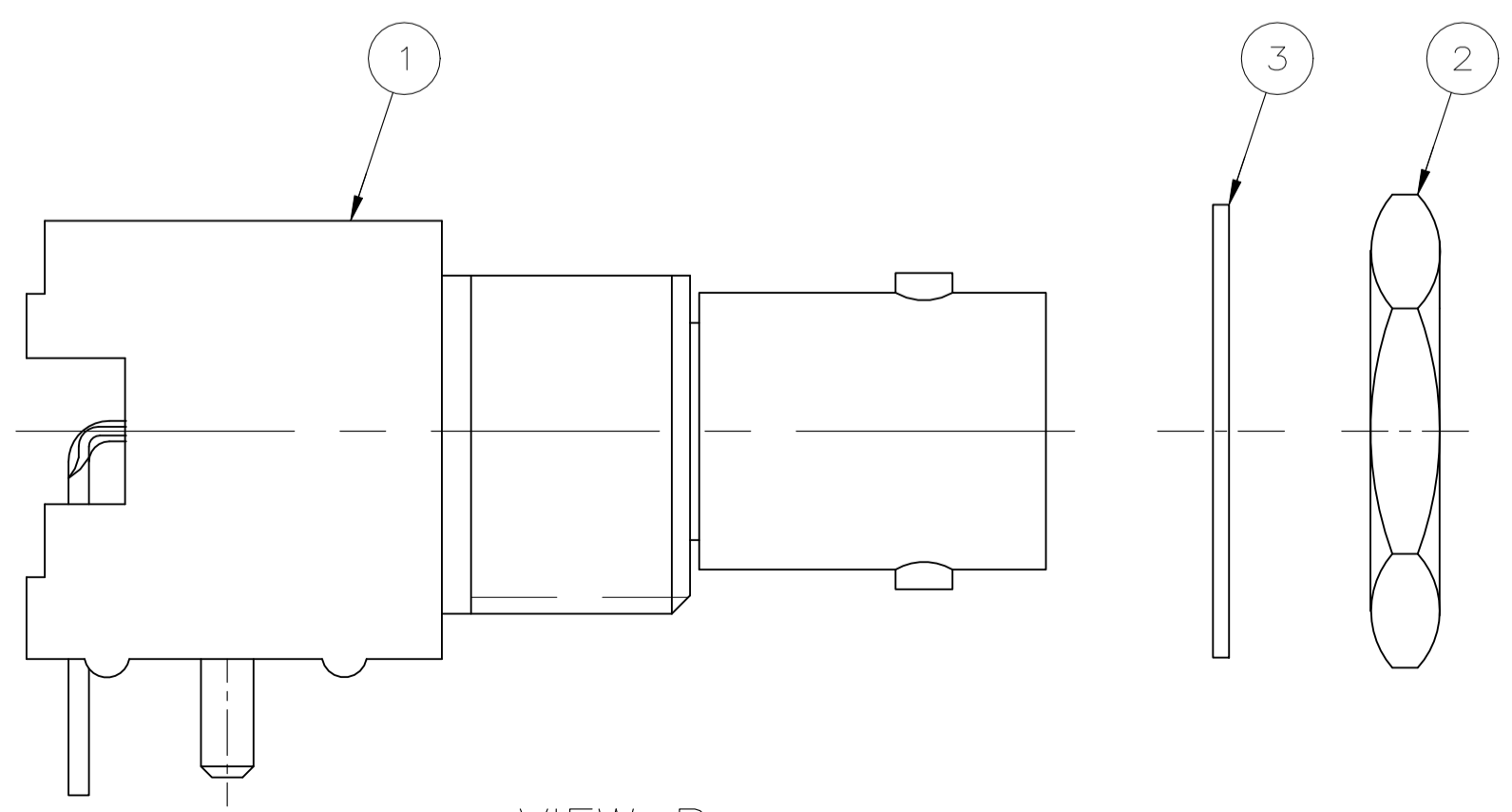

VIEW B

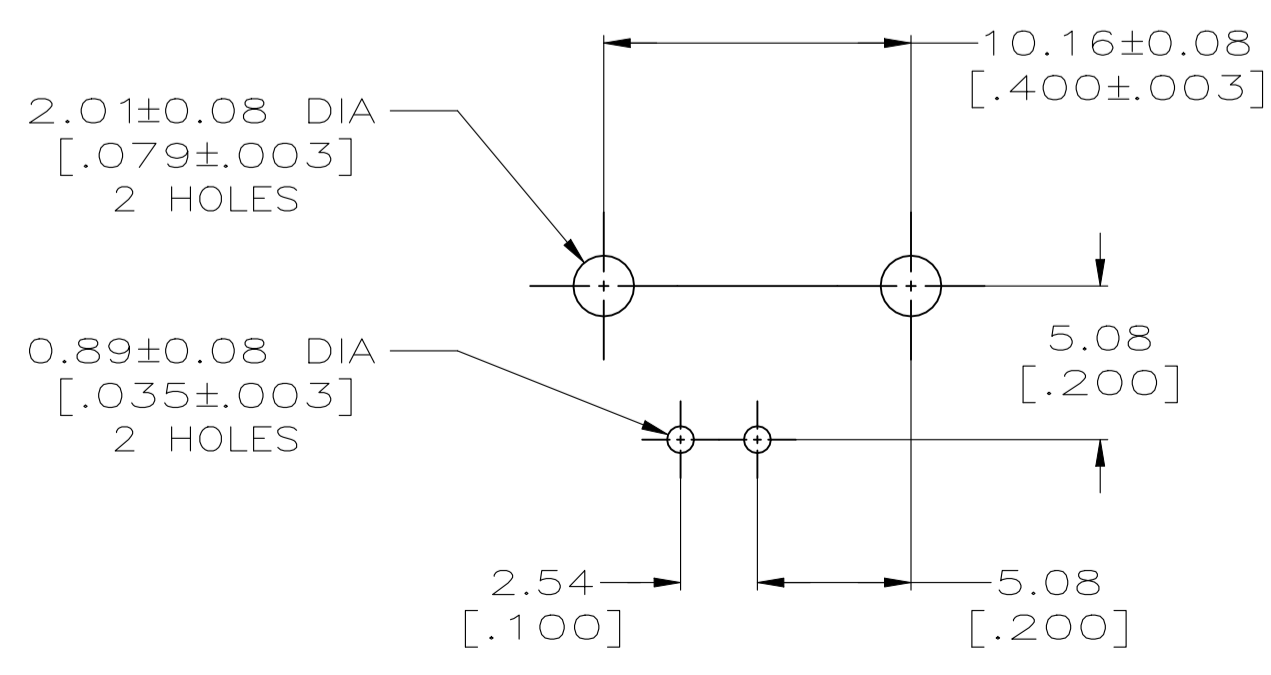

PCB CONFIGURATION

CONTACT FINISH	HOUSING MATERIAL	VIEW	LOCKWASHER	JAM NUT QTY=1	ASSEMBLY QTY=1	PART NUMBER
10	2	D	-	-	-	1-5227161-8
-	-	B	1-329632-2	1-329631-2	5227161-9	1-5227161-7
-	-	B	1-329632-2	1-329631-2	5227161-6	1-5227161-6
10	2	C	-	-	-	1-5227161-5
10	2	C	-	-	-	5227161-9
10	2	C	-	-	-	5227161-7
10	2	A	-	-	-	5227161-6
10	2	A	-	-	-	5227161-3
9	2	A	-	-	-	5227161-2
9	2	A	-	-	-	5227161-1

THIS DRAWING IS A CONTROLLED DOCUMENT.

DIMENSIONS: INCHES

TOLERANCES UNLESS OTHERWISE SPECIFIED:

0. PLC	± -
1. PLC	± -
2. PLC	± 0.05 [.002]
3. PLC	± -
4. PLC	± -
ANGLES	± -

MATERIAL: 10 2 3 4 5 6 7 8 9 10 11

FINISH: 10 11

WEIGHT: 0.000000

CUSTOMER DRAWING

DIN L. VARELA - DOCKS 20APR2005

CHK J. HAVENER 20APR2005

APVD S. BURKHOLDER 20APR2005

NAME: JACK, RIGHT ANGLE, 50 OHM, PCB, BNC

PRODUCT SPEC: 108-12078

APPLICATION SPEC: -

SIZE: A1

CAGE CODE: 00779

DRAWING NO: 5227161

RESTRICTED TO: -

SCALE: 4:1

SHEET: 1 of 1

REV: B4